

User manual

Doughnut maker

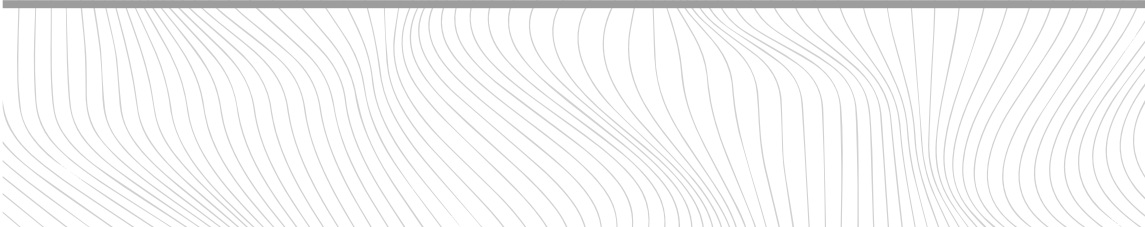

Description of parts

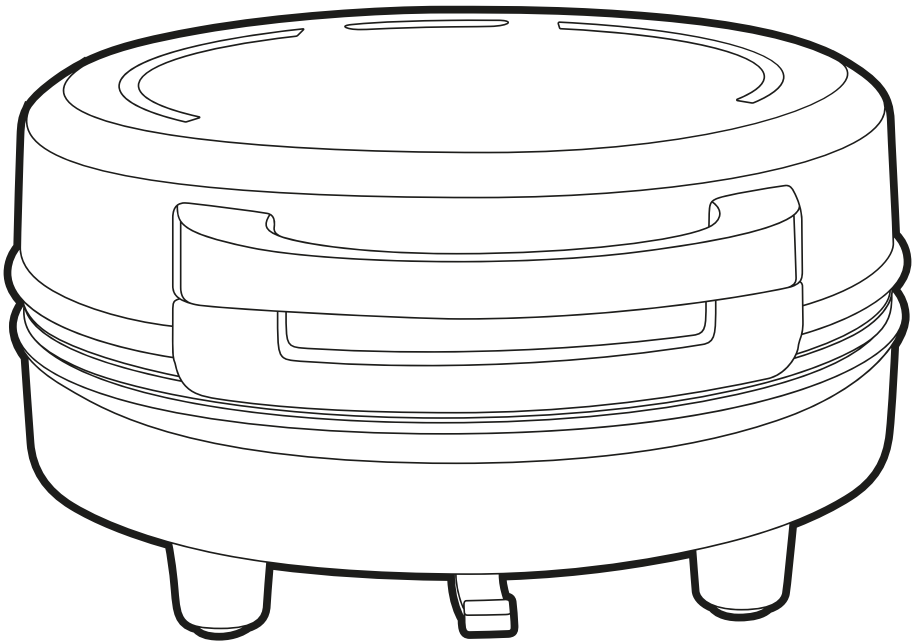
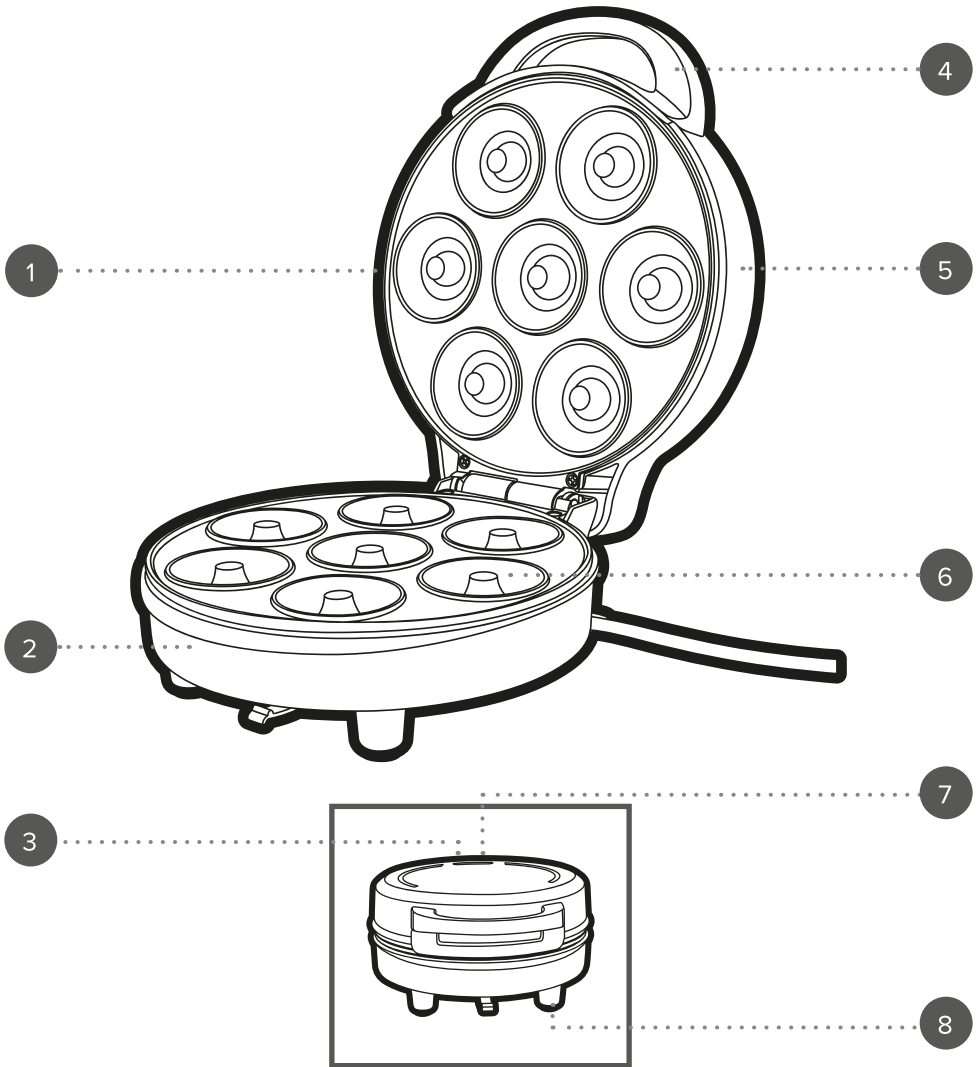

1. Doughnut maker main unit
2. Lower housing
3. Power indicator light
4. Handle

5. Upper housing
6. Non-stick coated cooking plates
7. Ready indicator light
8. Non-slip feet

Please retain instructions for future reference.

SAFETY INSTRUCTIONS

- When using electrical appliances, basic safety precautions should always be followed.
- Check that the voltage indicated on the rating plate corresponds with that of the local network before connecting the appliance to the mains power supply.
- This appliance can be used by children aged from 8 years and above and persons with reduced physical, sensory or mental capabilities and knowledge, if they have been supervised/instructed and understand the hazards involved.
- Children shall not play with the appliance.
- Children should not perform cleaning or user maintenance, unless they are older than 8 and supervised.
- This appliance is not a toy.
- If the power supply cord, plug or any part of the appliance is malfunctioning or if it has been dropped or damaged, cease using the product immediately to avoid potential injury.
- This appliance contains no user serviceable parts, only a qualified electrician should carry out repairs. Improper repairs may place the user at risk of harm.
- Keep the appliance and its power supply cord out of the reach of children.
- Keep the appliance out of the reach of children when it is switched on or cooling down.
- Keep the appliance and its power supply cord away from heat or sharp edges that could cause damage.
- Keep the power supply cord away from any parts of the appliance that may become hot during use.
- Keep the appliance away from other heat emitting appliances.
- Do not allow the power supply cord to hang over worktops, touch hot surfaces or become twisted.
- Do not immerse the electrical components of the appliance in water or any other liquid.
- Do not operate the appliance with wet hands or if any connections are wet.
- Do not leave the appliance unattended whilst connected to the mains power supply.
- Do not remove the appliance from the mains power supply by pulling the cord; switch it off and remove the plug by hand.
- Do not pull or carry the appliance by its power supply cord.
- Do not use the appliance for anything other than its intended use.
- Do not use any accessories other than those supplied.
- Do not use this appliance outdoors.
- Do not store the appliance in direct sunlight or in high humidity conditions.
- Do not move the appliance whilst it is in use.
- If this appliance falls or accidentally becomes immersed in water, unplug it from the wall outlet immediately. Do not reach into the water.
- Always unplug the appliance after use and ensure it has cooled fully before performing any cleaning, user maintenance or storing away.
- This appliance should not be operated by means of an external timer or separate remote-control system.

- Use of an extension cord with the appliance is not recommended.
- Always use the appliance on a stable, heat-resistant surface, at a height that is comfortable for the user.
- This appliance is intended for domestic use only. It should not be used for commercial purposes.



CAUTION: Hot surface – do not touch the hot section or heating components of the appliance.



WARNING: Keep the appliance away from flammable materials.

Care and maintenance

STEP 1: Before attempting any cleaning or maintenance, unplug the doughnut maker from the mains power supply and check that it has fully cooled.

STEP 2: Wipe the doughnut maker housing with a soft, damp cloth and dry thoroughly.

STEP 3: Remove baked-on food by applying a small amount of warm water mixed with a mild detergent to the non-stick coated cooking plates, then wipe them clean with a paper towel. Use a nonabrasive scourer if the food is difficult to remove.

Never use harsh or abrasive cleaning detergents or scourers to clean the doughnut maker or its accessories, as this could damage the surface.



NOTE: The doughnut maker should be cleaned after each use.

Before first use



NOTE: When using the doughnut maker for the first time, a slight smoke or odour may be emitted. This is normal and will soon subside. Allow for sufficient ventilation around the doughnut maker.

Using the doughnut maker

Before each use, carefully apply a thin coat of cooking oil to the non-stick coated cooking plates, rubbing it in with a paper towel. This will help to prolong the life of the non-stick coating and stop the doughnut from sticking.

STEP 1: Prepare the doughnut batter.

STEP 2: Plug in and switch on the doughnut maker at the mains power supply and preheat for approx. 2–3 minutes. The red power indicator light and green ready indicator light will illuminate, signalling that the doughnut maker is preheating. The green ready indicator light will switch off once the required temperature has been reached.

STEP 3: Using heat-resistant gloves, carefully open the lid.

STEP 4: Pour some of the batter into the centre of the lower non-stick coated cooking wells and then carefully close the lid. To avoid spillages, slowly pour a small amount of the batter into the centre of the plate and wait for it to evenly distribute before adding more.

STEP 5: Cook for approx. 5–8 minutes or until golden brown. Check periodically by carefully opening the lid. Avoid opening the doughnut maker before 4 minutes of cooking, as this will prevent

the doughnuts from rising. If needed, the doughnuts can be cooked a little while longer, until they are browned to preference.

STEP 6: Once cooking is complete, use heat-resistant oven gloves to carefully open the lid and then remove the doughnuts with a heat-resistant plastic or wooden spatula.

When creating multiple batches of doughnuts, close the lid after removing each batch to maintain the heat.

STEP 7: Switch off and unplug the doughnut maker from the mains power supply. Leave the lid open and allow to cool.



NOTE: Do not overfill the non-stick coated cooking plate; the batter will expand whilst cooking. It is recommended to fill by $\frac{2}{3}$. Always preheat the non-stick coated cooking plates before starting to cook. During use the green ready indicator light will cycle on and off to indicate that the doughnut maker is maintaining the temperature.



CAUTION: Exercise caution during cooking; the doughnut maker will emit steam.



WARNING: The doughnut maker and cooking plates get very hot during use; always use heat-resistant gloves to avoid injury.

Hints and tips

1. Avoid spillage by adding ingredients into the centre of each well.
2. If using a batter, slowly pour a small amount into the non-stick coated cooking plates and wait for it to distribute evenly before adding more, to avoid the risk of overfilling.
3. Sieving dry ingredients, such as flour, will help to make a smooth consistency and avoid any lumps.
4. Avoid opening the doughnut maker during cooking, as it will allow heat to escape and prevent bubbles from forming.
5. The best indicator as to when doughnuts are ready is when steam stops escaping from the doughnut maker.
6. Always use butter or cooking oil to precondition the non-stick coated cooking plates. Not only will this help to protect the non-stick coating, but it will also make it easier to remove the cooked doughnuts.
7. Using heat-resistant plastic or wooden utensils will help to protect the non-stick coating.
8. To save time when using the doughnut maker, prepare the ingredients and mixtures well in advance.

Storage

Before storing in a cool, dry place, check that the doughnut maker is cool, clean and dry. Never wrap the cord tightly around the doughnut maker; wrap it loosely to avoid causing damage.

Specifications

Product code: EK6222

Input: 220–240 V ~ 50–60 Hz

Output: 1000 W

RECIPES



Mini doughnuts

Ingredients

225 g plain flour
112 g sugar
1 egg
225 ml milk
4 tbsp cooking oil
1 tbsp baking powder
½ tsp vanilla essence

Method

Place the flour, sugar and baking powder together into a mixing bowl.

Create a well in the centre of the ingredients and add the milk, egg, vanilla and oil.

Using a mixer, mix the ingredients thoroughly to produce a smooth batter.

Preheat the doughnut maker and then carefully fill each doughnut well with batter. Ensure that each well is filled by ¾. Close the doughnut maker and bake for approx. 6–8 minutes or until golden brown.

Test the mini doughnut with a toothpick; if the toothpick comes out clean, the mini doughnuts are ready.

Carefully remove the mini doughnuts using a heat-resistant plastic or wooden spatula and leave to cool on a wire rack or serve warm.

Glazed doughnuts

Use the mini doughnuts recipe and add a glaze or coating of choice.

Glazes and coatings

Creamy glaze

Ingredients

220 g icing sugar
40 g butter
2 tbsp hot water
2 tsp vanilla sugar

Method

Heat the butter in a saucepan until melted, then remove from the heat.

Stir in the icing and vanilla sugar until the mixture is smooth.

Add one tbsp of water at a time until the desired consistency is achieved.

Dip the doughnuts into the creamy glaze, top with sprinkles (optional) and place on a wire rack to set.

Maple glaze

Ingredients

400 g icing sugar
2–2½ tbsp milk
½ tsp maple extract

Method

Sift the icing sugar into a bowl, then whisk in the maple extract and milk to make a glaze consistency.

Dip the doughnuts into the maple glaze, top with sprinkles (optional) and place on a wire rack to set.

Chocolate glaze

Ingredients

175 g icing sugar
2–2½ tbsp milk
2 tbsp cocoa powder
1 tsp vanilla essence

Method

Sift the icing sugar and cocoa powder into a bowl, then whisk in the vanilla essence and milk to make a glaze consistency.

Dip the doughnuts into the chocolate glaze, top with sprinkles (optional) and place on a wire rack to set.

Icing sugar coating

Place 400 g icing sugar in a paper bag or bowl. Add hot doughnuts to the bag or bowl and shake gently until coated.

Iced doughnuts

Use the mini doughnuts recipe and add frosting.

Vanilla frosting

Ingredients

300 g sifted icing sugar
56 g butter, melted
1–1½ tbsp hot water
1 tsp vanilla essence
Food colouring, as desired

Method

Sift the icing sugar into a bowl, then whisk in the melted butter, vanilla essence and hot water to create a frosting. Add food colouring as desired.

Coat the doughnuts with the vanilla frosting, top with sprinkles (optional) and place on a wire rack to cool.

Ice cream doughnuts

Ingredients

Flavoured ice cream, as desired
Rainbow sprinkles (optional)

Method

Slice the doughnuts horizontally across the middle. Place a tablespoon of ice cream between the doughnut halves. Roll the sides in sprinkles (optional) and freeze or enjoy immediately.

Matcha doughnuts

Ingredients

165 g plain flour
75 g caster sugar
55 g coconut oil
1 large egg
235 ml almond milk
½ tsp matcha powder
½ tsp vanilla essence
¼ tsp baking powder
¼ tsp sea salt
⅛ tsp nutmeg
⅛ baking soda

Method

In a medium bowl, mix the coconut oil, sugar and egg. Sift in the baking powder, baking soda, matcha powder, nutmeg, salt and mix to combine. Add the vanilla essence and mix.

Begin adding the flour and milk, alternating between them until combined into a smooth batter. Preheat the doughnut maker and then carefully fill each doughnut well with batter. Ensure that each well is filled by 2/3. Close the doughnut maker and bake for approx. 5–8 minutes or until golden brown.

Test the doughnut with a toothpick; if the toothpick comes out clean, the mini doughnuts are ready.

Carefully remove the doughnuts using a heat-resistant plastic or wooden spatula and leave to cool on a wire rack or serve warm.

Chocolate doughnuts

Ingredients

225 g plain flour
112 g sugar
112 g cocoa powder
1 egg
50 ml milk
1 tbsp baking powder
2 tbsp cooking oil
1 tsp vanilla essence

Method

Place the flour, baking powder, sugar and cocoa together into a mixing bowl.

Create a well in the centre of the ingredients and add the milk, egg, vanilla and oil.

Mix the ingredients thoroughly until combined into a smooth batter.

Preheat the doughnut maker and then carefully fill each doughnut well with batter. Ensure that each well is filled by ⅔. Close the doughnut maker and bake for approx. 5–8 minutes or until golden brown.

Test the doughnut with a toothpick; if the toothpick comes out clean, the mini doughnuts are ready.

Carefully remove the doughnuts using a heat-resistant plastic or wooden spatula and leave to cool on a wire rack or serve warm.



Disposal of Waste Batteries and Electrical and Electronic Equipment



This symbol on the product, its batteries or its packaging means that this product and any batteries it contains must not be disposed of with household waste. Instead, it is the user's responsibility to hand this over to an applicable collection point for the recycling of batteries and electrical and electronic equipment. This separate collection and recycling will help to conserve natural resources and prevent potential negative consequences for human health and the environment due to the possible presence of hazardous substances in batteries and electrical and electronic equipment, which could be caused by inappropriate disposal. Some retailers provide take-back services which allow the user to return exhausted equipment for appropriate disposal. **It is the user's responsibility to delete any data on electrical and electronic equipment prior to disposal.** For more information about where to drop batteries, electrical and electronic waste off, please contact the local city/municipality office, household waste disposal service, or the retailer.

Manufactured by:
Ultimate Products UK Ltd.,
Victoria Street, Manchester OL9 0DD. **UK.**
Ultimate Products Europe Ltd.,
19 Baggot Street Lower, Dublin D02 X658. **ROI.**

MADE IN CHINA.

CD150324/MD000000/V1